

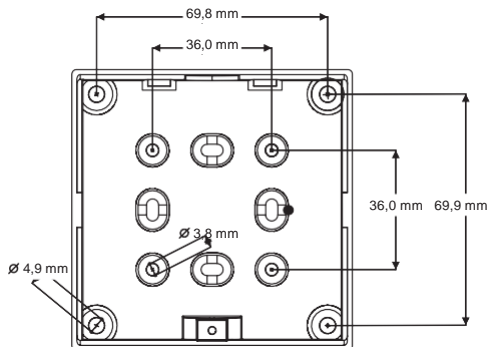

TW-SHOK

| | | | | | |
|---|---|--|--------|--|----------|
| | | | | | |
| DMV2C | 85 x 85 x 55,2 mm | 250V AC / 5 A OU-OU-O 30V DC / 4A | 0,2 kg | 40 utilização em interior only for indoor use uso en interiores | 0 +50 °C |
| | inclui chaves de reset (2x) Comes with reset key (2x) incluye llaves de reinicio (2x) | <p>OPCIONAL - OPTIONAL</p> <p>Tampa de Protecção Protection cover Cubierta protectora</p> | | | |
| ST 3,5x25 /X15 | Parafuso da tampa (1x) Cover screw (1x) Tornillo de cubierta (1x) | | | | |
| Estado original: desarmado - Factory setting: disarmed | | | | | |

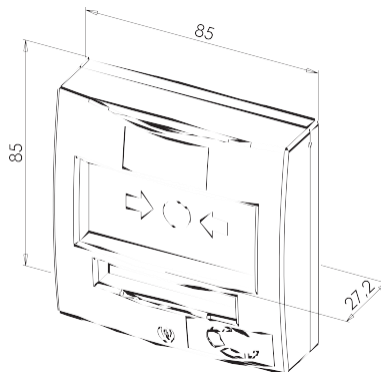
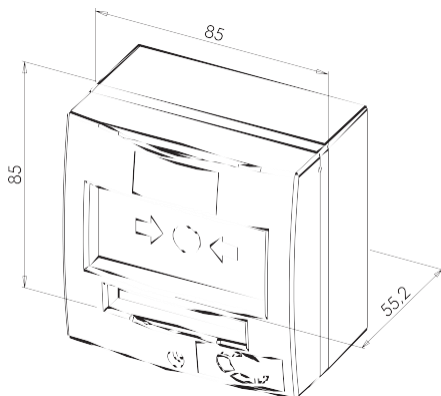

ATENÇÃO:

- ▶ **Teste de funcionamento :**
Proceder a um teste inicial (activação/desactivação) antes de colocar em funcionamento.
- ▶ **Manutenção :**
Recomendado um teste anual de funcionamento.

CAUTION:

- ▶ **Functional test:**
Proceed to prior functional test (activation/deactivation) before final commissioning.
- ▶ **Maintenance:**
A functional test is recommended each year.

ATENCIÓN:

- ▶ **Prueba de funcionamiento:**
Realice una prueba inicial (activación / desactivación) antes de la puesta en marcha.
- ▶ **Mantenimiento:**
Se recomienda una prueba anual.

MONTAGEM EMBUTIDA
MORTICE MOUNTING
MONTAJE EMPOTRADO

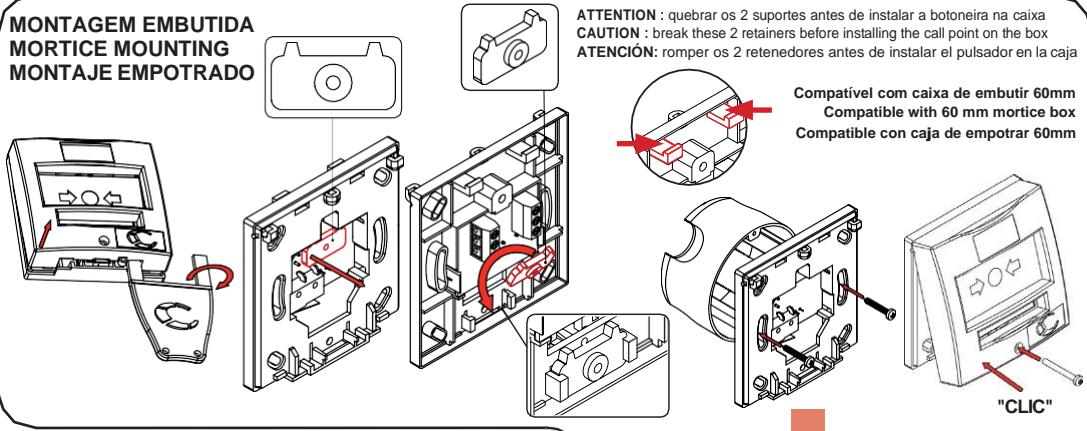

ATTENTION : quebrar os 2 suportes antes de instalar a botoneira na caixa
CAUTION : break these 2 retainers before installing the call point on the box
ATENCIÓN: romper os 2 retenedores antes de instalar el pulsador en la caja

Compatível com caixa de embutir 60mm
 Compatible with 60 mm mortice box
 Compatible con caja de empotrar 60mm

"CLIC"

MONTAGEM À SUPERFÍCIE
SURFACE MOUNTING
MONTAJE EN SUPERFICIE

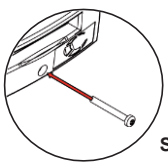

ST 3,5x25
 /X15

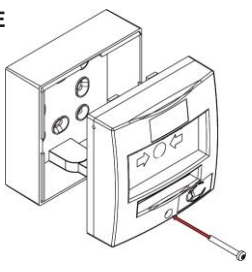

Furação para caixas quadradas
 Drilling for square boxes
 Perforación para cajas cuadradas

MONTAGEM DA TAMPA DE PROTECÇÃO
MOUNTING OF THE PROTECTION COVER
MONTAJE DE LA CUBIERTA DE PROTECCIÓN

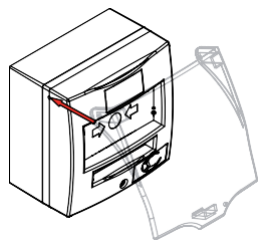

REARMAMENTO MANUAL DA BOTONEIRA
MANUAL RESET OF THE CALL POINT
REARMAMENTO MANUAL DEL PULSADOR



DIAGRAMA DE CONEXÃO - CONNECTION DIAGRAM - DIAGRAMA DE CONEXIÓN

Conectar enquanto está desligado - Connecting whilst idle - Conexión mientras está inactivo

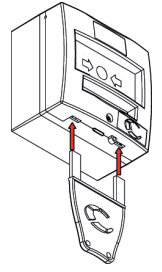
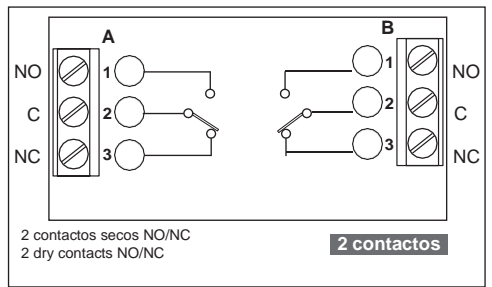
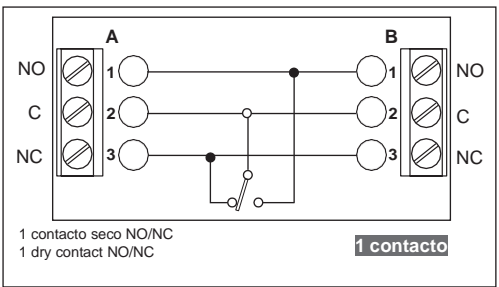

Sección dos cabos :
 - monocondutores
 - multicondutores

Cross section of the cables :
 - single conductor cables
 - multiconductor cables

Sección de los cables:
 - monocondutores
 - multicondutores

$\leq 1,5 \text{ mm}^2$
 $\leq 1 \text{ mm}^2$