



# Triplow

TW-611-EX



## FICHA TÉCNICA

# RETENTOR ELECTROMAGNÉTICO DE PAREDE Anti-explosão



- Modelo: TW-611-EX
- Dimensão: 97,5 x 75 x 40 (mm)
- Voltagem: 12 ou 24 VDC
- Corrente em trabalho: 0,13 A
- Força de tração: 650Kg
- IP: 68

## Dimensões

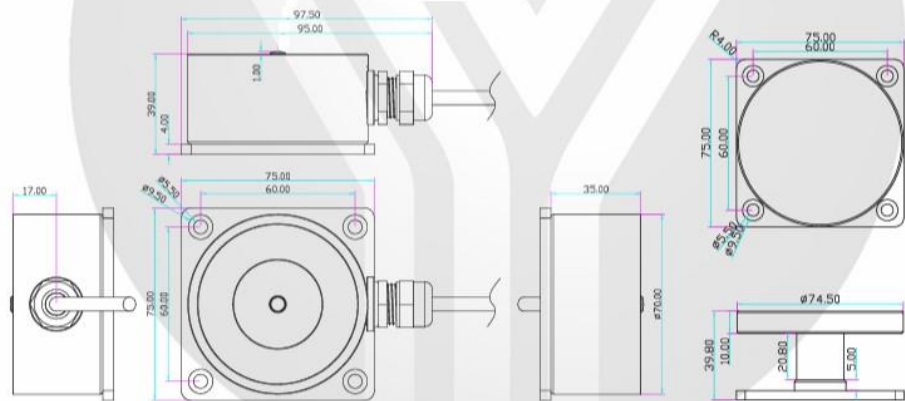

## Installation

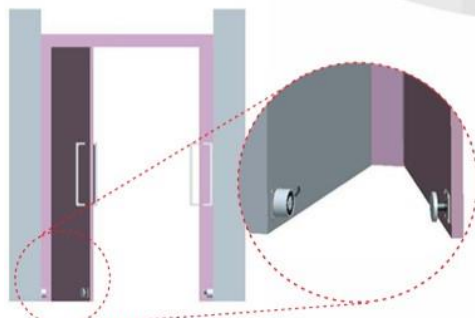

## Wiring Instruction

### DC 12V

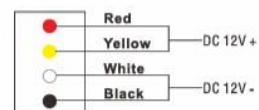

### DC 24V

