

PH-450/ PH-900 Handle Lock Series

Electromagnetic Lock Installation Instruction

Website: www.gianni.com.tw
E-mail: inquiry@gianni.com.tw

A Technical Specification

Specification	
Operating Voltage	PH-450:12/24VDC PH-900:12/24VDC x2
Current Draw	PH-450:500mA/12VDC 250mA/24VDC PH-900:500mA/12VDC x2 250mA/24VDC x2 (at temperature 20°C)
Operating Temperature	-10~55°C(14~131°F)
Relay Rating	3A/12VDC
Door Status Output	0.2A/12VDC (PH-450MDS-TD) (PH-900MDS-TD)
Holding Force	PH-450: 600 lbs (approx. 272 kg) PH-900: 600 lbs x2 (approx. 272 kg x2)
Lock Surface Temperature	≤ ambient temperature ±20°C
Special Finishes for magnet and armature plate	Zinc plated

B Connecting Diagram

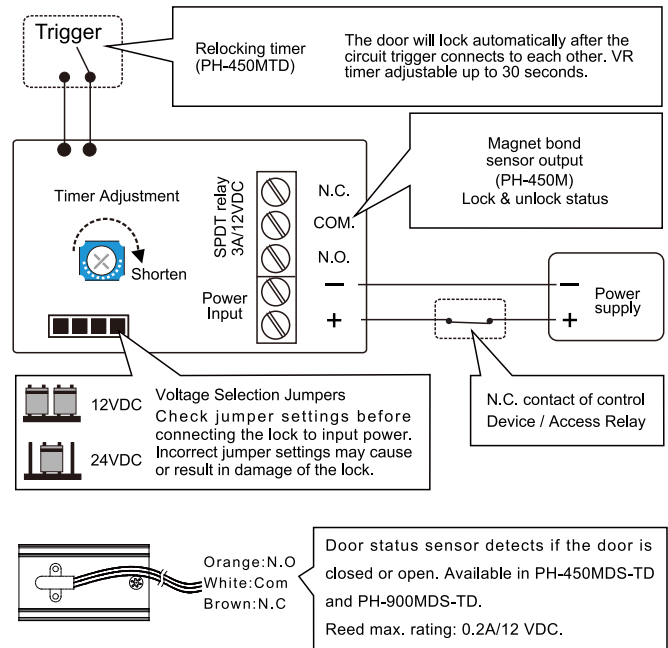

C Dimensions & Accessories

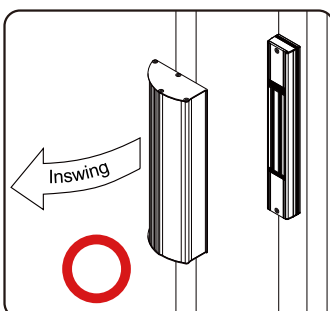
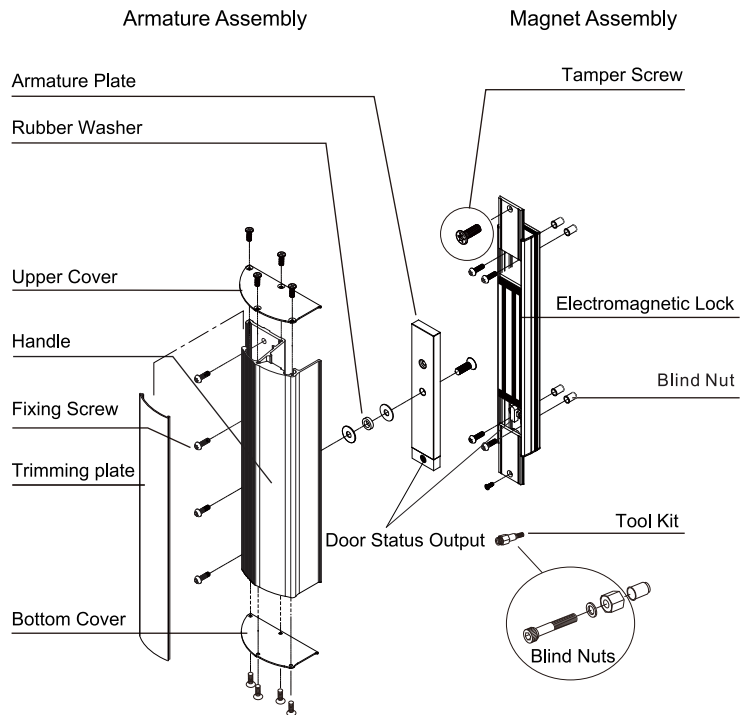
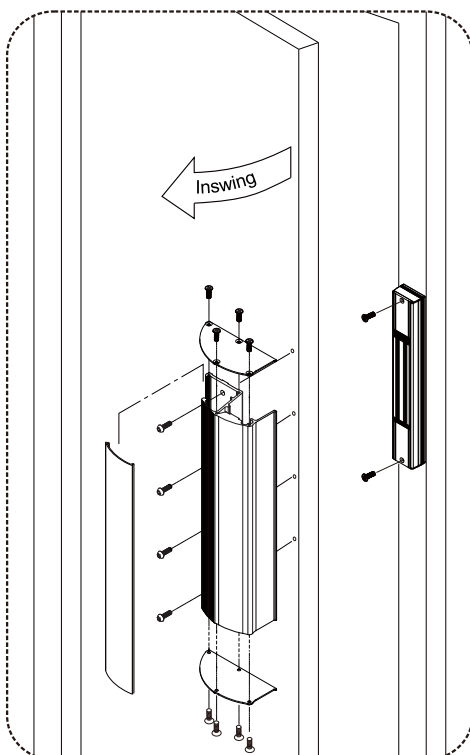

Notice that PH-450/PH-900 series of maglocks should be installed on "inswing" doors and frames for the sake of security.

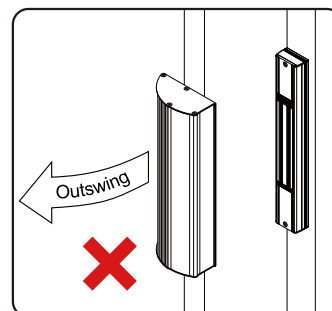

Installing the maglock on outswing doors/frames will pose security problems.

D Regular Installation

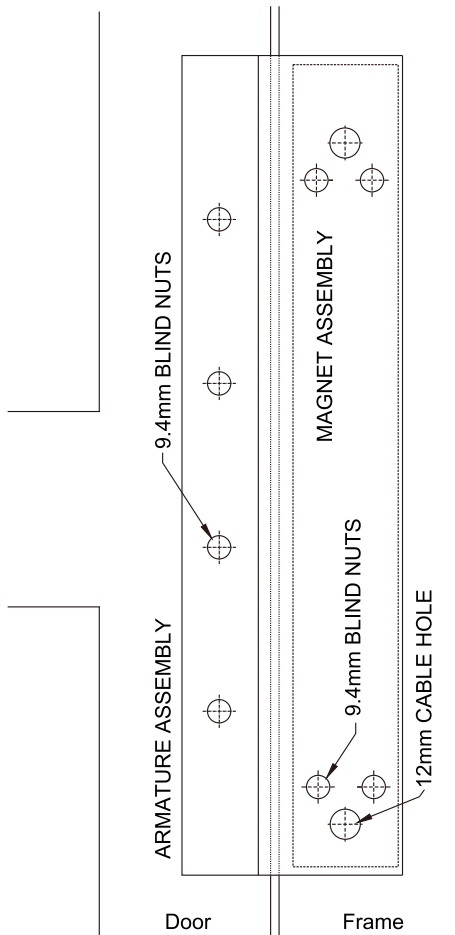

Installation Instruction:

- 1 Close the door and make sure the door and the door frame are at the same level of height; otherwise, it is necessary to add extra iron boards to make the door or the door frame at the same level.
- 2 Stick the templates to the corresponding positions on the door and frame. (Make sure the gap between the door and frame is within the limit set by installation.)
- 3 Drill the holes for cables and screws according to the templates.
- 4 Fix the blind nuts (see illustration below) to secure the maglock.
- 5 Wire the maglock.
- 6 Fix the armature plate. Plug in the maglock. Close the door and test the holding force. Add rubber washers if necessary to adjust the gap between the armature plate and maglock.

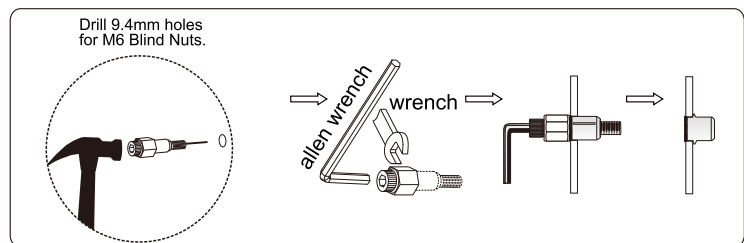

Drill 9.4mm holes for M6 Blind Nuts.

Insert the Blind Nut into fixing screw and separate holes.

Use the allen wrench to slowly tighten the Blind Nut. (Don't tighten the nuts too firmly.)

Keep wrenching the Blind Nut so that it remains permanently fixed in the frame. Remove the tool.

E Important Notes

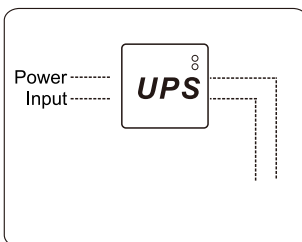

The electromagnetic lock is fail-safe and will require a power supply unit equipped with battery back up for fear that power failure may increase security risks.

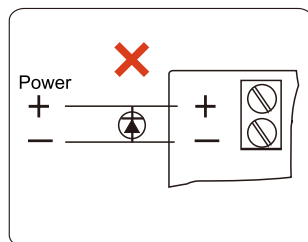

Do not install a diode or MOV in parallel with any magnetic lock. A diode will cause a delay when releasing the door.

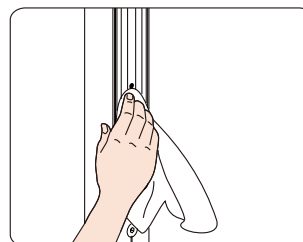

Apply a light coat of a silicon lubricant to prevent the maglock from rusting. Wipe off the excess.

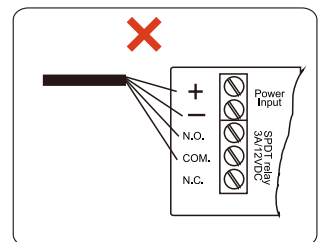

Do not strand power wires and signal wires in the same cable or conduit.

F Trouble Shooting

Problem	Possible Cause	Solution
Door does not lock	No power	Make sure the wires are securely tightened to the correct terminal block
		Check that the power supply unit is connected and operating properly
		Make sure the lock switch is wired correctly
Reduced holding force	Poor contact between electromagnet and armature plate	Make sure the surface of the armature plate is in good shape
		Make sure the rubber washer is inserted behind the armature plate
		Make sure the contact surfaces of the electromagnet and armature plate are clean and free from dust
	Low voltage or incorrect voltage setting	Check the setting of power input volume
Sensor output is not functioning	A secondary diode was installed across the electromagnet	Remove any diode installed across the magnet for "spike" suppression. (The magnet is fitted with a metal oxide varistor to prevent back EMF)
	Misalignment between the armature plate and its magnet	Check the faces of armature plate and the maglock are aligned face-to-face