



TRIPLO W
Criamos Segurança!

Ficha Técnica / Manual do Utilizador

SE1APC

Trinco Eléctrico para barras antipânico (NC) c/ sinal



Especificações Técnicas

DIMENSÕES (mm)	45 x 155 x 35
PESO (kg)	0,6
FORÇA DE RETENÇÃO (DaN)	400 DaN
VOLTAGEM	12-24 V AC/DC +/- 10%
CONSUMO DE ENERGIA	12 - 24V AC: 250 / 150 mA 12 - 24V DC: 300 / 600 mA
PROTECÇÃO IP	IP 42

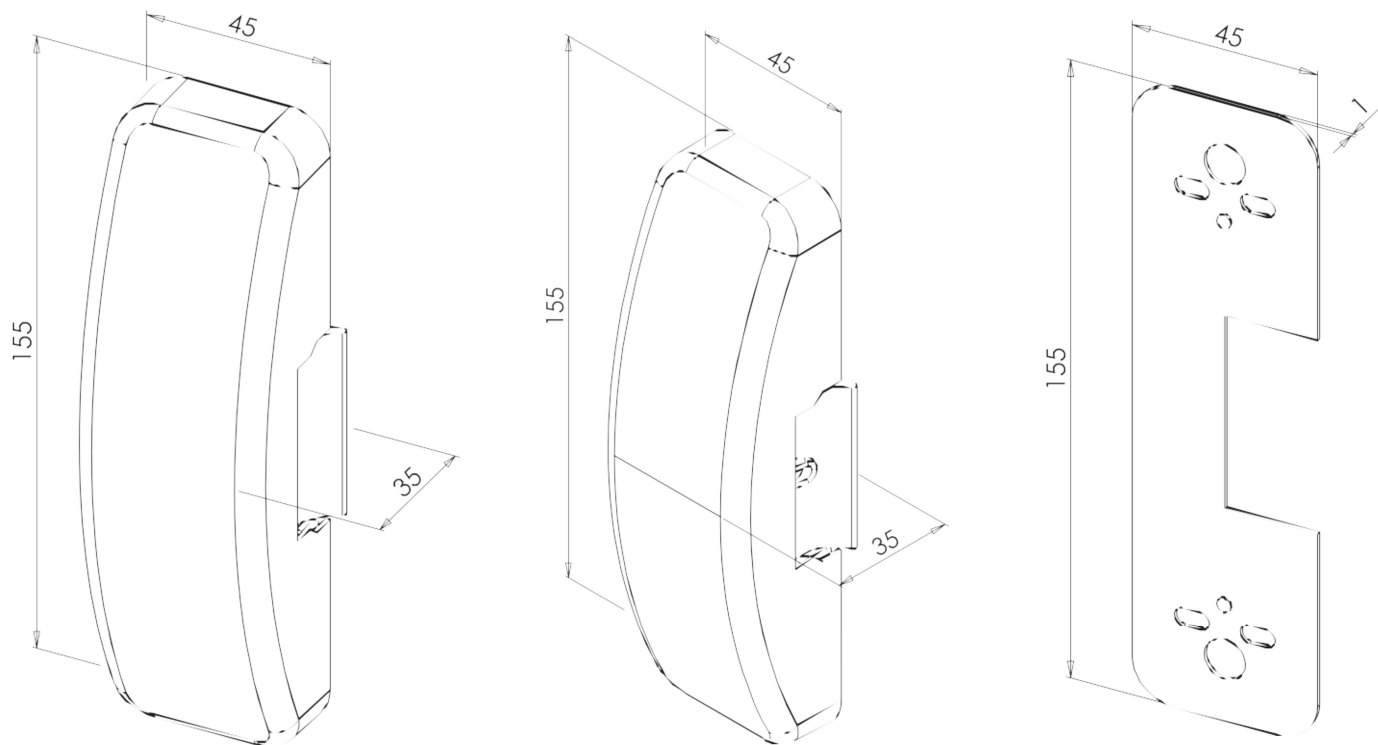

Instalação

ST 4,2 x 25 mm

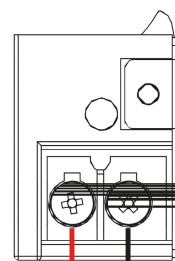
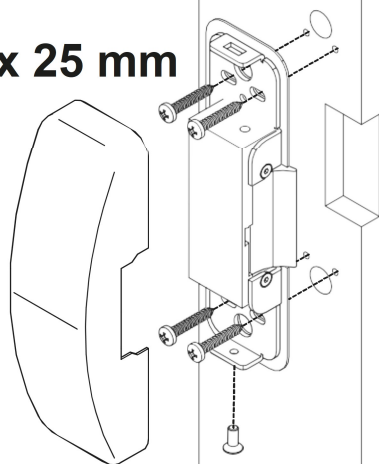

+ -

12-24V AC/DC
Sem Polarização

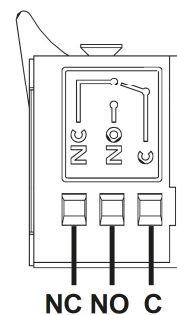

NC NO C

*Parafusos não fornecidos