

DATA SHEET

Card Reading Terminal for Hotels



MF READER

- Model: MF READER
- Controller power supply: 12V DC
- Current: <100mA
- Temperature: -20°C - 70°C
- Card Type: Mifare 13,56 MHz
- Compatible with hotel software
- Dimensions: 156 x 75 x 22 mm
- Weight: 500g

Dimensions



Units: mm





Installation

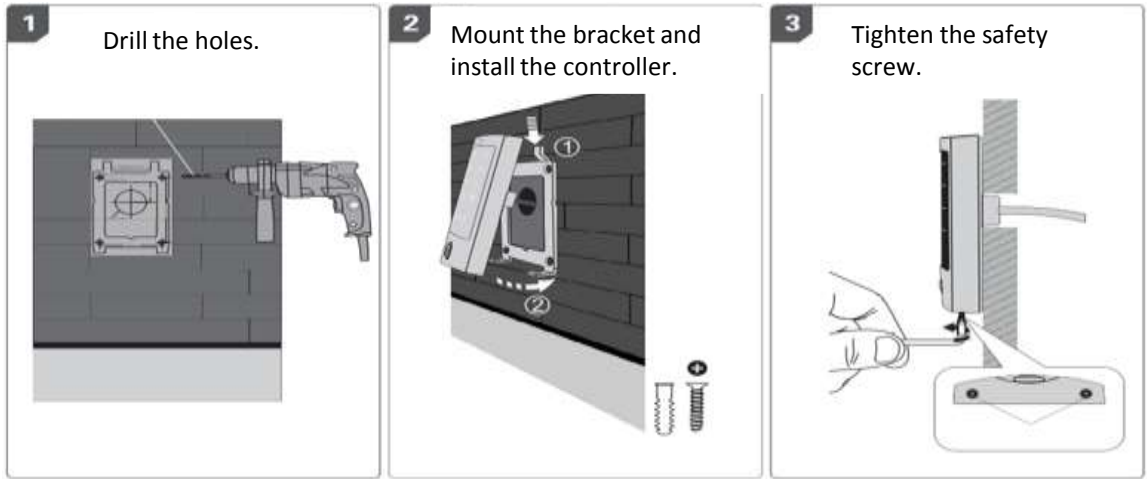

Warranty

Every product marketed by Triplow W Lda., have a two-year warranty for manufacturing defects.

Every equipment sold is checked at our facilities for defects; and if it is unrepairable, it shall be replaced with a new product, according to the corresponding warranty.

For additional information check our conditions of sale at:

<http://www.triplow.pt/loja/termos-e-condicoes>

