



TRIPLO W  
Criamos Segurança!

# TW300KFP

Guia de Instalação  
Manual do Utilizador

Impressão Digital, Teclado Touch, Leitor  
de Cartões com ligação Bluetooth/Wi-Fi



Bluetooth  
4.1



\* apenas com m  
gateway

[www.triplow.pt](http://www.triplow.pt)

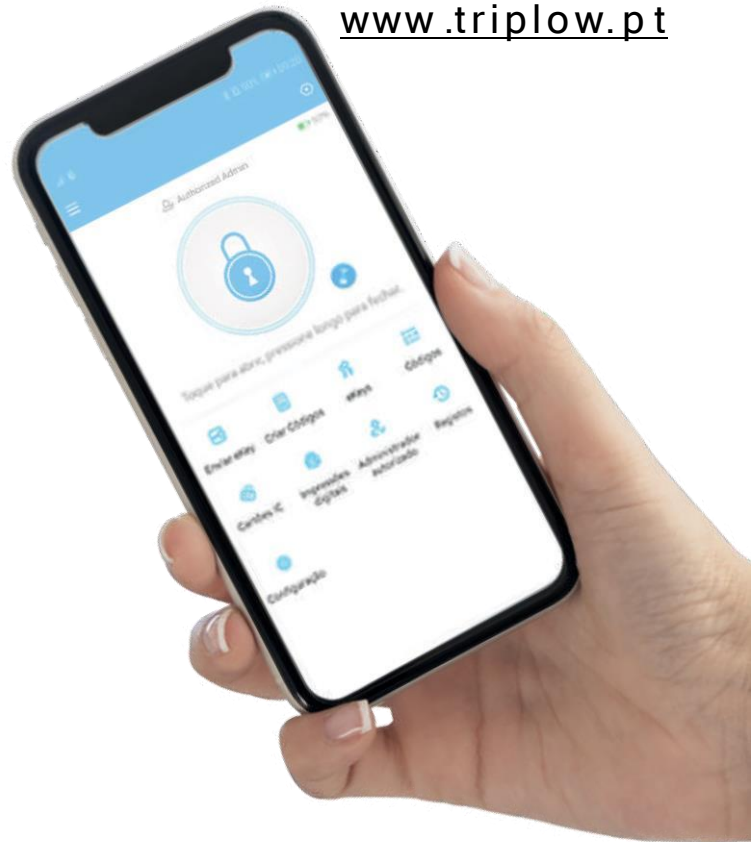

Leia o manual com atenção antes da instalação e guarde-o para uso futuro.

# Dimensões

1

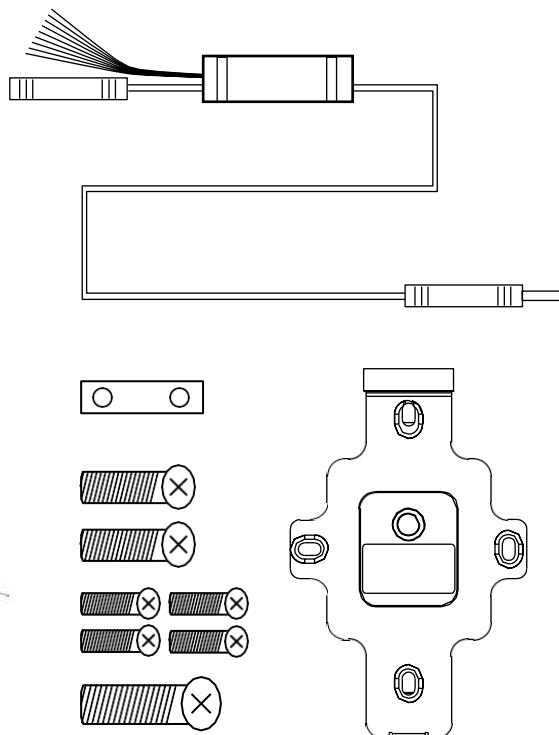
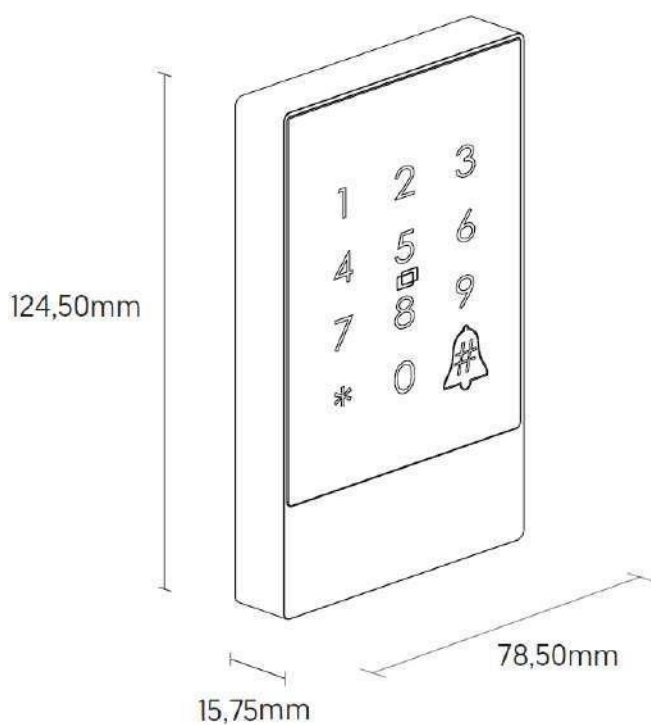

NÃO INCLuíDO  
(opcional)  
Gateway para Wi-Fi

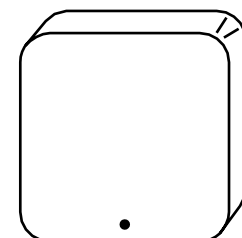

TW-GATE

# Especificações Técnicas

MATERIAL	Alumínio
COR	Prata / Preto
DIMENSÕES (mm)	125 x 79 x 18.5 mm
PESO (KG)	1.1 Kg
GRAU DE PROTECÇÃO	IP66
TIPOS DE ABERTURA	Impressão Digital, Bluetooth 4.1, APP, Código, Cartão de Proximidade
SOFTWARE COMPATÍVEL	TTLock, TTHotel, TTRenting
VOLTAGEM	12V DC
CONSUMO (FUNCIONAMENTO)	1 A
CONSUMO (STANDBY)	15 mA
CAPACIDADE DE DADOS	100 Cartões
TEMPERATURA DE TRABALHO (°C)	-20° ~ +65°
HUMIDADE DE TRABALHO (%)	30% ~ 95%
DISTÂNCIA DE LEITURA	< 55mm
TEMPO RECONHECIMENTO (/s)	1.5 s
GATEWAY	Não incluído, necessário para Wi-Fi

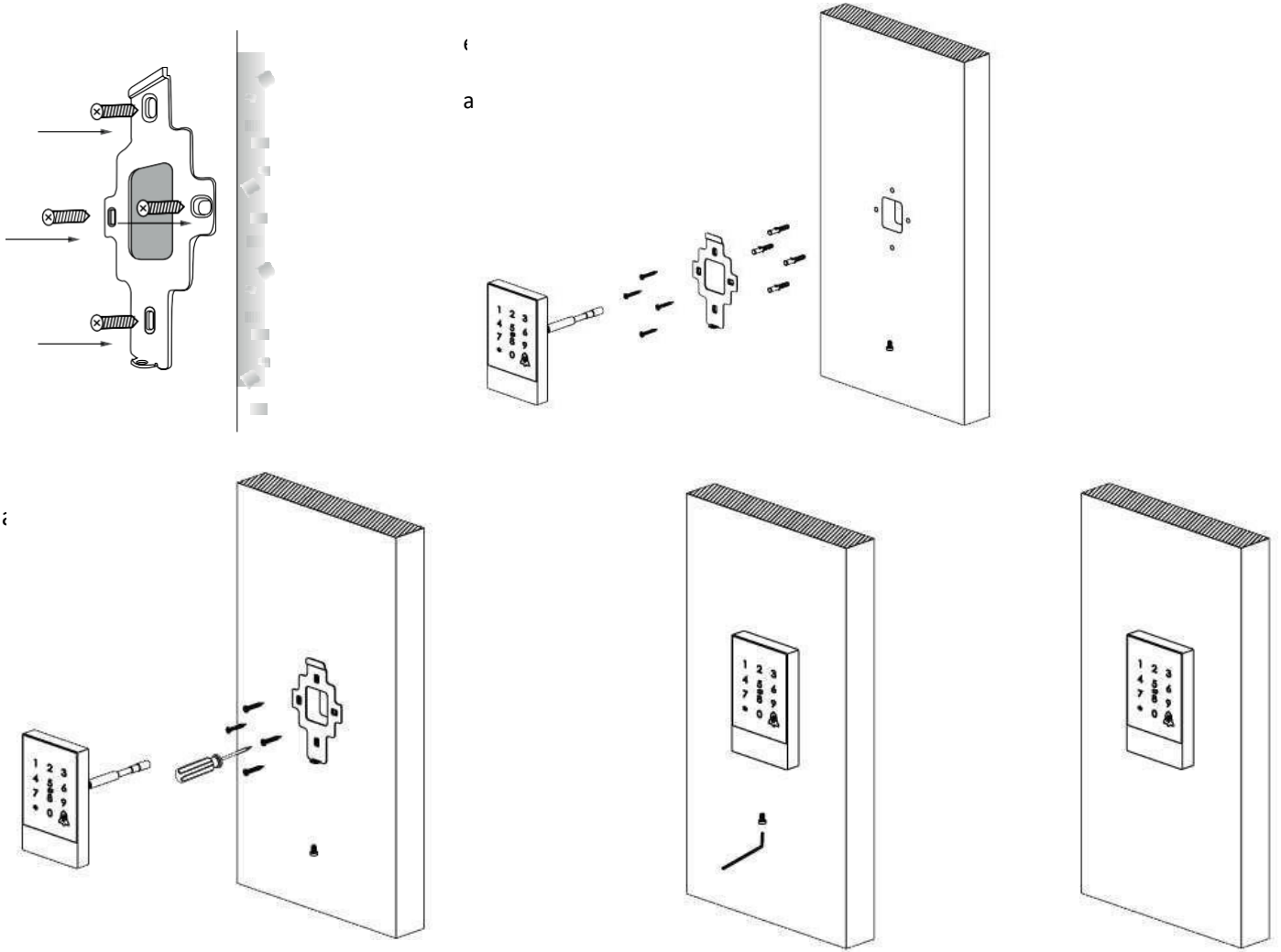

## Fonte de Alimentação

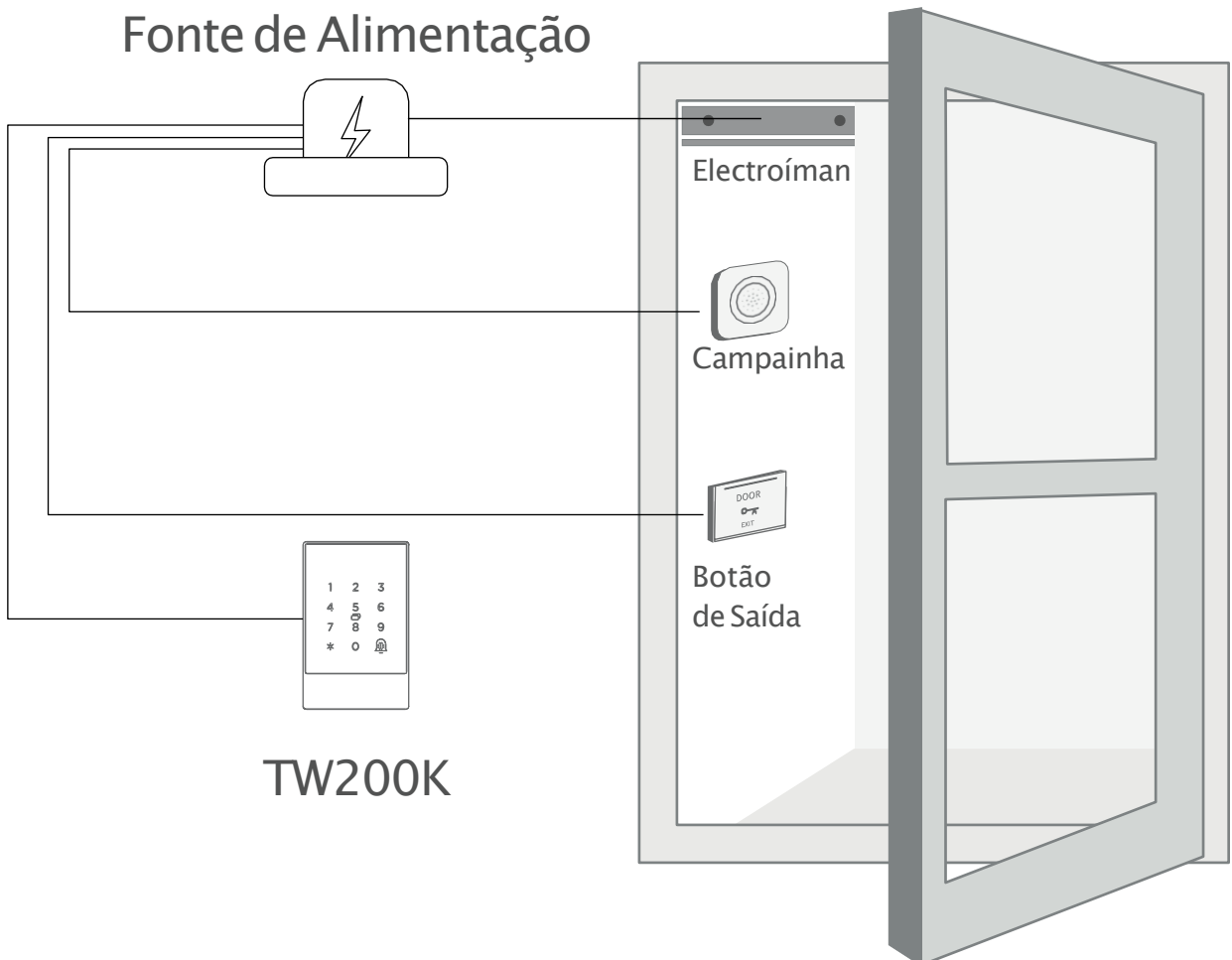

# Esquema Eléctrico

## Fonte de Alimentação K80

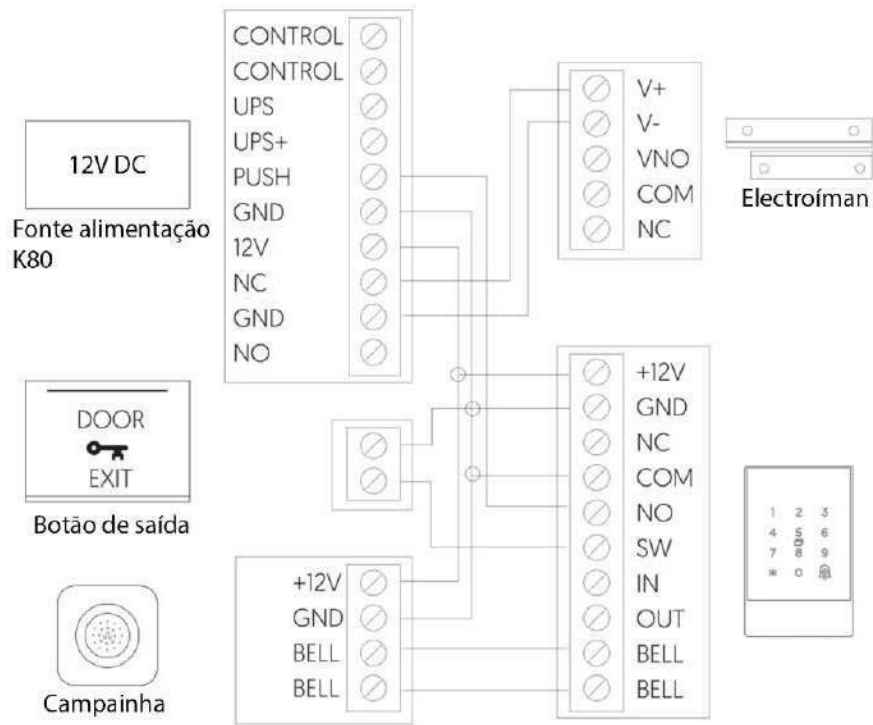

## Fonte de Alimentação Comum

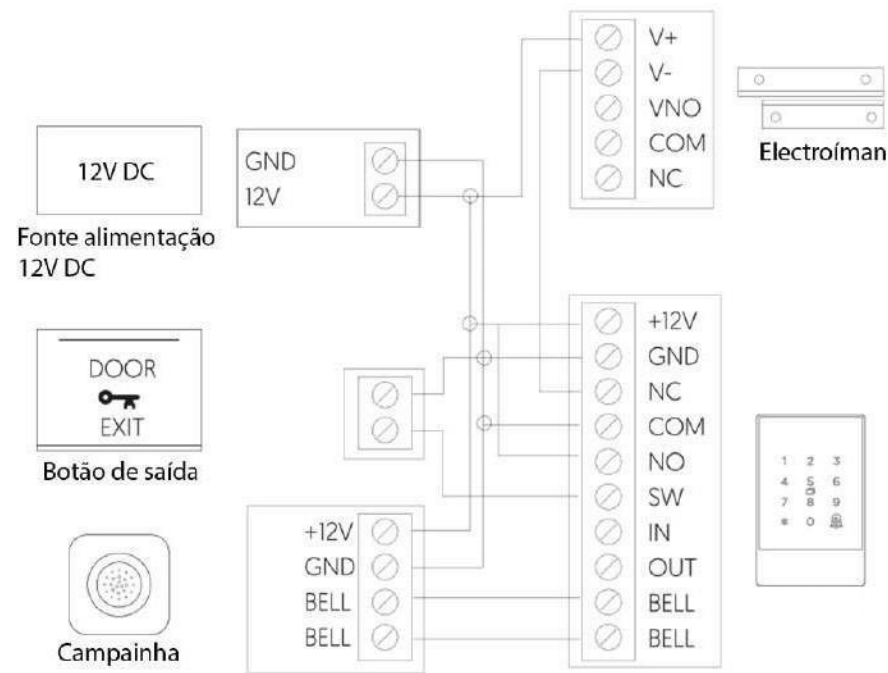

- Vermelho: 12V DC
- Preto: GND
- Amarelo: NC
- Branco: COM
- Verde: NO
- Azul: SW
- Laranja: BELL 1
- Cinzento: BELL 2

DC12V

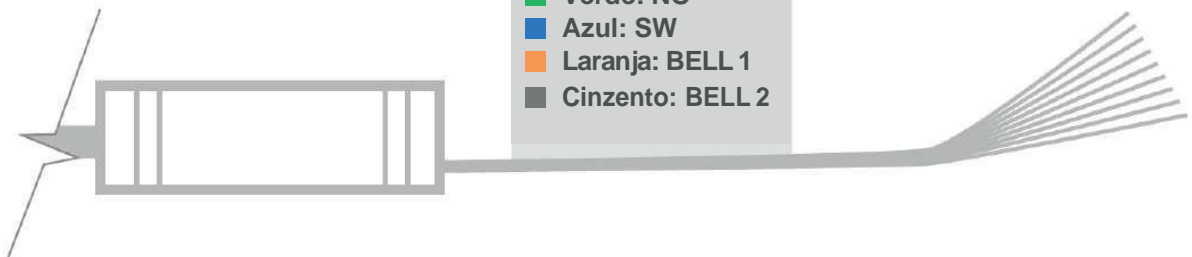

# Reiniciar

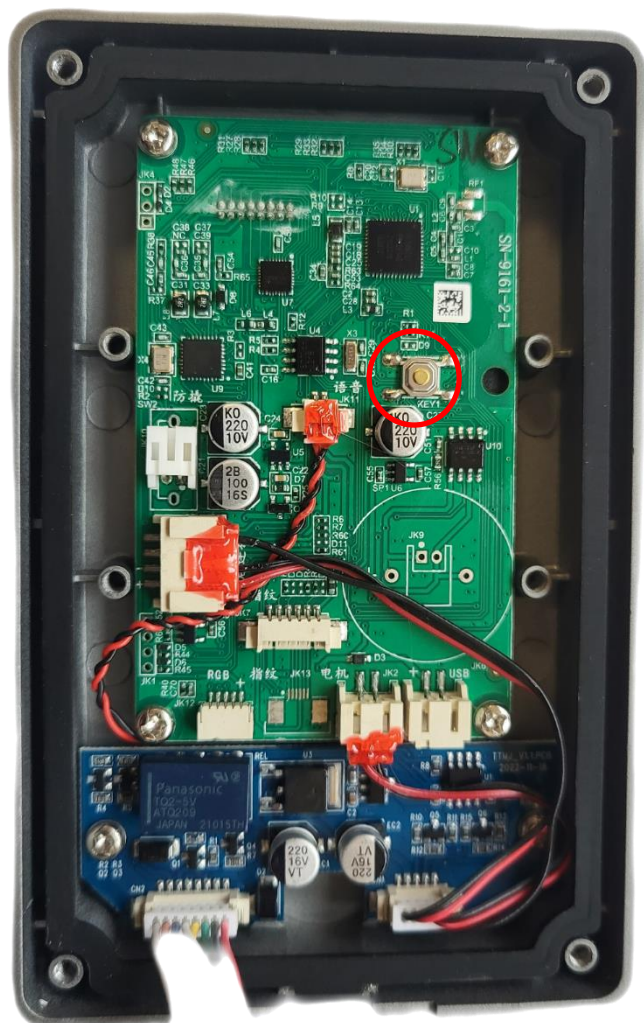

Para reiniciar o produto, deve desaparafusar a parte de trás.

Com o equipamento ligado, pressionar uns segundos o botão dourado indicado na imagem ao lado e inserir o código 000# no teclado.

O processo será bem sucedido se no final o aparelho disser “Deleted administrator successful”