



# Triplo W

## FICHA TÉCNICA

YEH-210



Trinco eléctrico de embutir para portas ou janelas de correr

### Características Técnicas

Dimensões	Fechadura: 79 x 45,5 x 34,3 (mm) Trinco e espelho: 91 x 30 x 25,85 (mm)
Peso (Kg)	0.35 Kg
Força	300 Kg
Voltagem (V)	12V DC
Corrente (mA)	12V/ 100mA
Temperatura de trabalho	-40~50°C
Humidade de trabalho	0~95%

### Dimensões

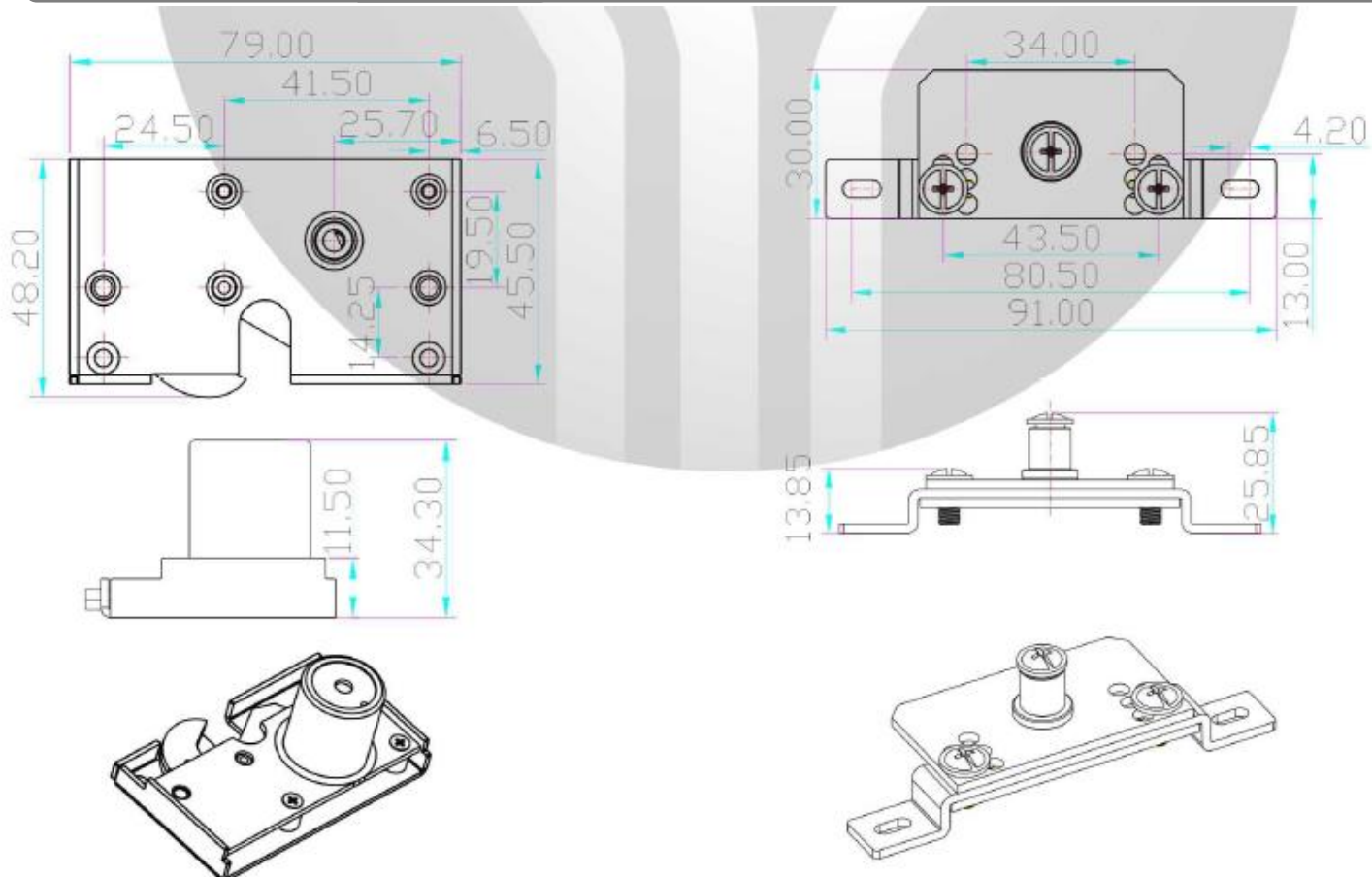



# Triplo W

## FICHA TÉCNICA

Mini trinco eléctrico de estilo europeo

YEH-210



### Instalação

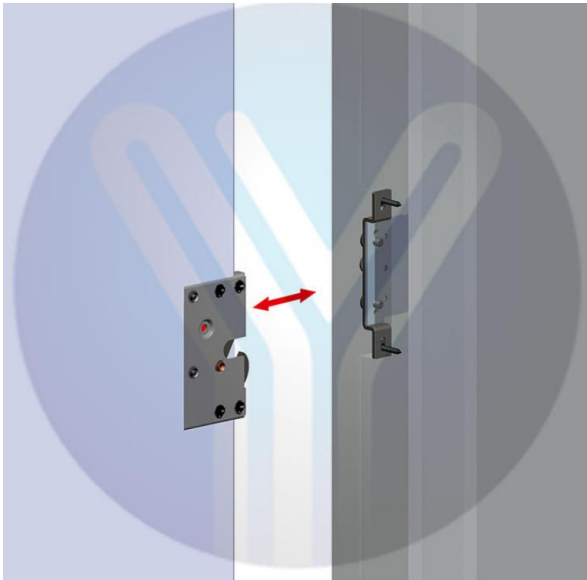

Sliding rail door

### Esquema eléctrico

